

# Vertical single-shaft mixer Type VM

patented

The ideal mixing quality for dry, moist and viscous materials at variable filling levels in a short mixing time

The mixer can be designed to conform to FDA-standards to be used as a sterile mixer and reactor which also meets EHEDG requirements and the 3-A Sanitary Standards.

Mixing tool driven and supported only from above

Manual feeding hopper on demand

Washing nozzle

SinConvex® helical mixing tool provides excellent mixing quality

Chopper to improve the mixing process by deagglomeration

Mixing vessel and mixing tool welded and polished without gaps, inside with fillet

Mixing chamber: ATEX Zone 20

OmgaSeal®

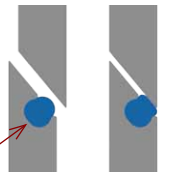

Large inspection door without dead space designed by Clever-Cut®

Standard connection flange with outlet flap, seals without dead space

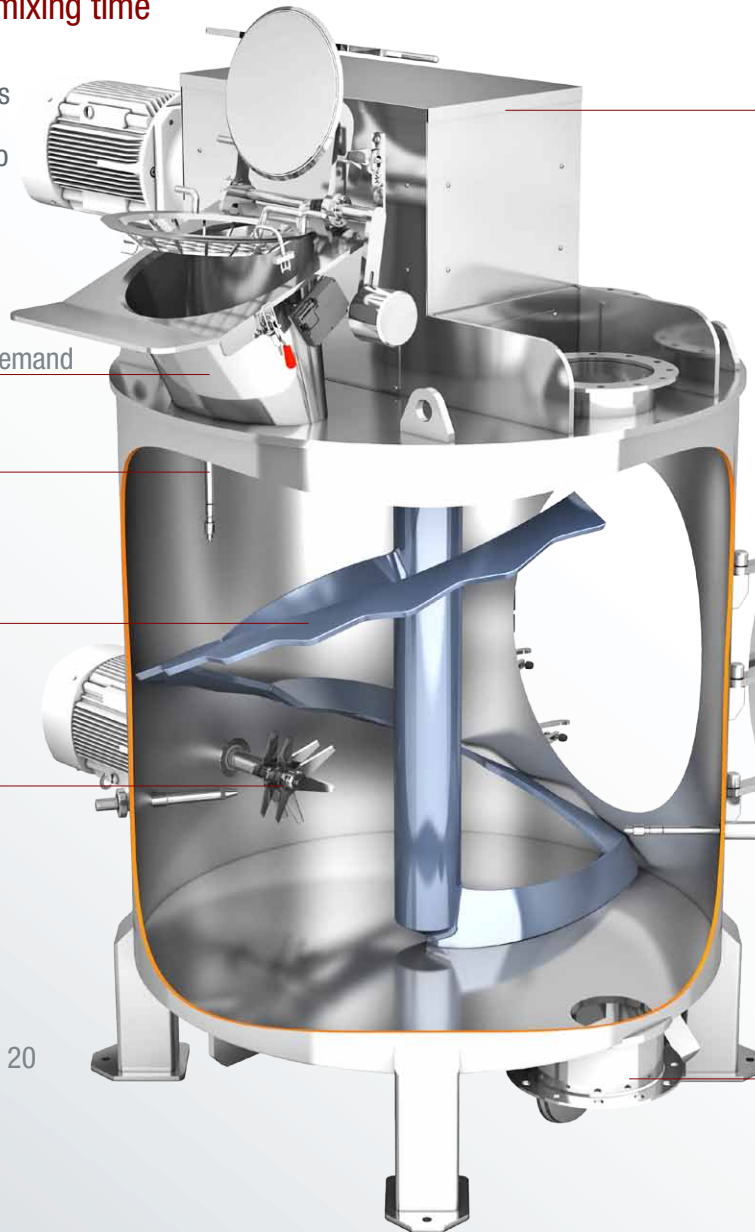

VM 2000 for food colouring

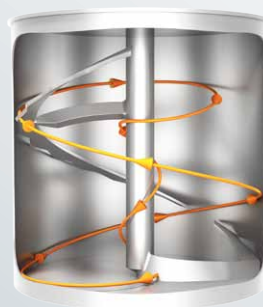

Three-dimensional rearrangement

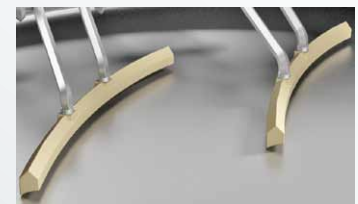

ComDisc® (patented) for complete discharge: During the final phase of the discharging, they sweep the ground. Thus, the last remnants are discharged without segregation.

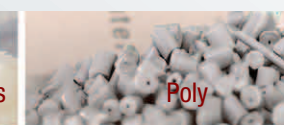

## User Benefits

- ✓ This precision mixer is universally applicable to almost all types of dry, moist or suspended solids.
- ✓ The mixer guarantees ideal mixing qualities.
- ✓ Especially compact and robust design.
- ✓ Mixing tool driven and supported only from above. Everything is fully welded and polished without gaps.
- ✓ The inspection door is especially hygienic - manufactured according to the Clever-Cut® process with OmegaSeal® - and seals permanently free of dead space. On request also vacuum-tight or against overpressure.

## Piloting

amixon® places special importance on the pilot phase in the test centre. Your mixing processes are simulated here. This way, we support you in your product development phase. amixon® has a main test center in Paderborn (Germany). Further test centers are situated in Japan, Thailand, India and the USA.



## Technical Data

Vertical single-shaft mixer <b>Type VM</b> The type designation is equal to the batch size in liters. Ideal mixing even at low filling levels.	Approximate gross volume of the mixer	Approximate dimensions of the standard machines Please ask for detailed dimension sheets!					The rotational frequency can vary widely from about 0,8 m/s to about 3,5 m/s. Usually vertical single-shaft mixers operate at low speed.  about		The drive power required can vary widely depending on the bulk density, flow characteristics, rotational frequency and the processing task (such as deagglomeration).		Weight may vary considerably depending on the size of the drive and the type of design. The additional dynamic loads are very low.
		A	B	C	D	E	from	to	from	to	
		Liter = dm <sup>3</sup>	Liter	mm	mm	mm	mm	mm	mm	Rotation per Minute	
100	130	350	624	1200	620	145	28	105	1	5	560
200	260	420	774	1300	770	145	22	83	3	8	680
300	390	450	724	1400	900	145	19	73	5	15	720
400	520	450	904	1400	900	145	17	66	7	21	800
500	650	450	894	1550	1020	145	16	61	8	27	1200
600	780	480	1030	1700	1000	145	15	57	10	31	1400
800	1040	500	980	1850	1200	145	14	52	12	40	1700
1000	1300	550	1210	1900	1200	145	13	46	14	48	2000
1500	1950	600	1380	2200	1370	145	11	42	19	64	2560
2000	2600	700	1530	2300	1510	145	10	38	22	78	3200
2500	3250	730	1570	2400	1550	145	10	35	26	90	3500
3000	3890	750	1750	2600	1730	145	9	33	29	101	4000
4000	5180	750	1910	2900	1890	145	8	30	34	120	4240
5000	6470	850	2050	3200	2030	145	8	28	38	137	5840
6000	7760	850	2190	3200	2170	145	7	26	43	153	6240
7000	9040	900	2090	3400	2424	145	7	25	47	167	6800
8000	10330	900	2410	3400	2394	145	6	24	50	180	7600
9000	11610	1000	2040	3750	2824	145	6	23	54	193	8000
10000	12890	1100	2200	4100	2824	145	6	22	57	205	8800
12000	15460	1100	2540	4100	2824	145	6	21	63	227	10400
15000	19300	1100	3150	4400	2824	145	5	19	71	257	12000
17000	21860	1250	2850	4500	3194	145	5	19	76	275	13600
20000	25700	1500	2750	4800	3454	145	5	18	83	300	16000
25000	32080	1600	3600	5100	3454	145	4	16	94	339	20800
30000	38470	1600	4170	5100	3454	145	4	15	104	374	24800
40000	51210	1600	4300	5300	3844	145	4	14	121	436	33600

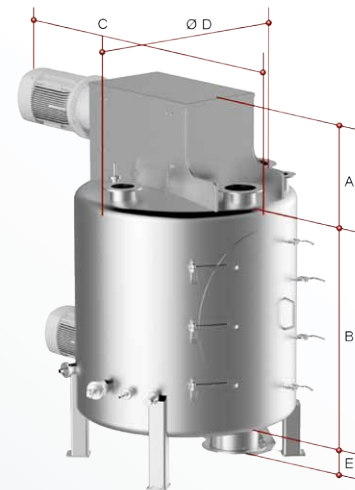

- Usually the vessel dimensions are relatively cubic, so that the height of the cylinder corresponds to the diameter. If desired, amixon® can modify the proportions: "low profile" if the height is limited or "slim profile" if the available ground area is limited.
- As a welding specialist, amixon® is qualified by European, Japanese and American authorities with regard to different materials. The materials in contact with the mixing goods are either mild steel S355J2Ge, Hardox, austenitic stainless steels 1.4301, 1.4541, 1.4571, 1.4404, 1.4539, 1.4529, Duplex stainless steels 1.4462, 1.4162, 1.4363, and Alloy 59-2.4605, Hastelloy C22 and nickel.
- The mixers meet the highest hygienic requirements and comply with the EHEDG guidelines for dry and wet cleaning. The mixers also meet the FDA hygiene guidelines and the design requirements of 3-A Sanitary Standards.



amixon GmbH  
Halberstädter Straße 55  
33106 Paderborn  
Germany

Tel. +49 (0) 52 51 / 68 88 88-0  
Fax +49 (0) 52 51 / 68 88 88-999  
E-Mail sales@amixon.com  
www.amixon.com



amixon® manufactures high precision mixers, vacuum mix-dryers, synthesis reactors and granulators with maximum fabrication depth. All components of the amixon®-mixers are made in Germany. The production of the machines takes place exclusively in the amixon®-factory in Paderborn, Germany.

© by amixon GmbH, Paderborn. Reprinting or transfer to electronic media only permitted after written approval. We reserve the right to make changes due to progress in process engineering and manufacturing technology.